

Achieving Philosophical Perfection:
Omar Khayyam's Successful Replacement of Euclid's Parallel Postulate

Amanda Nethington

University of Missouri – Kansas City

aenxw7@mail.umkc.edu

Home Address: 978 Oakmoor Drive, Fenton, MO 63026

(314) 403-4535

23 March 2019

Supervising Instructor: Richard Delaware

In the mathematical world, no volume could be considered more studied, more criticized, or more influential than Euclid's *Elements* [4, p. 51]. Compiled and organized circa 300 BCE by Greek mathematician Euclid of Alexandria, the *Elements* consists of 13 books, or chapters, and contains the majority of the knowledge of geometry understood at the time. Little is known about Euclid's life, but his work on the *Elements* put him on the map as an influential and distinguished mathematician [4, p. 51]. This fame did not come without criticism, however. A number of the entries in the *Elements* have been criticized by countless mathematicians since its publishing for small, but crucial, holes in the logic, or for certain statements that should be addressed as postulates. Our discussion will revolve around objections to the fifth postulate of the first book, referred to later as the parallel postulate.

Euclid begins the first book of the *Elements* with five postulates, or accepted statements, which are referenced through the remainder of the *Elements*. Much of the work in ancient Greek mathematics revolved around geometric construction using only a straightedge and a compass [4, p. 40]. The Greeks were dedicated to solving geometric problems in the most logical and minimalistic way possible. Therefore, creating geometry in its purest form. So, the first three postulates simply encode facts about the use of a straightedge or compass. The fourth postulate addresses the uniqueness of the right angle. The fifth and final postulate of the first book caught the eye of some mathematicians. The five postulates are as follows: [4, p. 53]

1. To draw a straight line from any point to any point. [A straightedge property.]
2. To produce a finite straight line continuously in a straight line. [A straightedge property.]
3. To describe a circle with any center and distance [radius]. [A compass property.]

4. That all right angles are equal to one another. [Meaning that all right angles have the same “standard” magnitude. Euclid wisely understood that it was necessary for him to accept this as a postulate. [2]]
5. That, if a straight line intersecting two straight lines makes the interior angles on the same side less than two right angles [less than 180°], the two straight lines, if produced [extended] indefinitely, meet on that side on which are the angles less than two right angles.

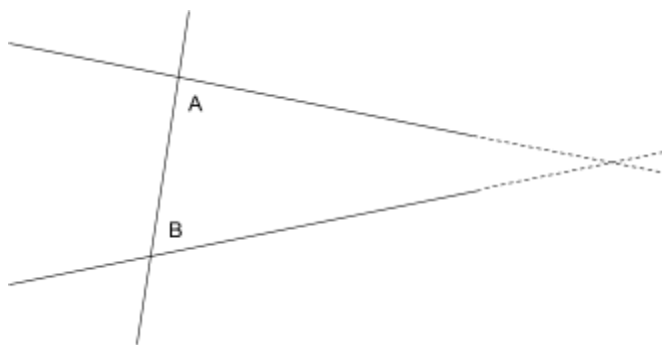

The fifth postulate is illustrated above. If two lines are intersected by a third, and $\angle A + \angle B < 180^\circ$, then the two lines will meet on the side of angles A and B , creating a triangle. This postulate became known as the parallel postulate, since any two lines which did not meet these criteria would be considered parallel. In some ways, this fifth postulate seems acceptable. However, need this be considered a postulate? Mathematicians contemplated this for centuries.

Among those was Proclus, a first century Greek writer [4, p. 51]. Proclus claimed that the fifth postulate did not fit with the other four due to its complexity. He stated that it was, in fact, a theorem, “and the converse of it is actually proved by Euclid himself as a theorem” as well. [6, p. 1]. The theorem mentioned by Proclus is proposition 17 of the same book, which states that “the

sum of two angles of a triangle is less than two right angles” [6, p. 1]. This proposition is illustrated below.

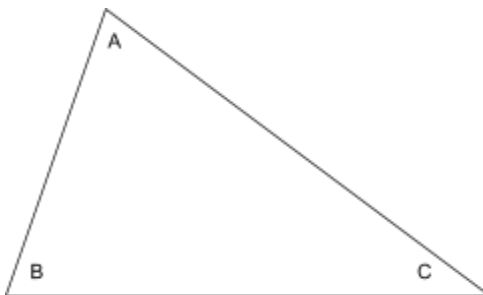

Proposition 17 stated that if any two of the interior angles A, B, and C of the triangle were added together, their sum would be less than 180° . It is clear that this is simply the converse of the parallel postulate, which made that postulate feel even more out of place next to the other four. Proclus presented an excellent point. If Euclid was able to prove I-17, he surely should be able to prove its converse, the parallel postulate [4, p. 1].

For centuries, “courageous souls” attempted the parallel postulate, either trying to “prove the postulate, to derive it from other more obvious postulates, or else to replace it by some principles which are less complicated” [9, p. 282]. Nonetheless, countless mathematicians tried and failed for one reason or another, to prove the parallel postulate [8, p. 183]. Some tried to prove the parallel postulate by contradiction, others by recruiting the ideas of motion, and some by replacing it all together within Euclid’s *Elements* [3, p. 112].

By the 11th century, this postulate sparked the attention of Persian (current day Nishapur, Iran) mathematician Umar al-Khayyami (1048 - 1131), known in the west as Omar Khayyam. Within mathematics, Khayyam expanded the knowledge of cubic equations, real numbers, the binomial theorem, and the length of a calendar year [7]. In addition to his works as a mathematician, Khayyam was a well-known philosopher, astronomer, and poet. His most famous

work in poetry, the *Rubaiyat*, can be found translated and paraphrased into English by Edward Fitzgerald, completed in 1859 [5].

Khayyam recognized the failures of other mathematicians from the start, claiming that, “every one of them has postulated something which was not easier to admit than this [the fifth postulate itself]” [8, p. 219]. He also stated that their error was due to “their disregarding the principles taken from the Philosopher, and their relying upon the extent which Euclid had supplied in the beginning of the first Book” [8, p. 224]. Khayyam explains that modern mathematicians had failed to prove the parallel postulate because they were only relying on the original four postulates in Book I of Euclid’s *Elements*. However, relying on these four postulates alone is not enough, because “the propositions which are required prior to geometry are numerous” [8, p. 224]. After seeing the countless attempts and failures of other mathematicians, Khayyam did not attempt to prove Euclid’s famous parallel postulate from the other four postulates.

Instead, Khayyam believed that Euclid had begun the *Elements* in a manner that was incomplete. He claimed “the reason why Euclid has disregarded the demonstration of this premise and has postulated it [the fifth postulate], is that he was relying upon the principles taken from the Philosopher [Aristotle] regarding the notion of straight line and of rectilineal angle” [8, p. 222]. It is important to note that Khayyam is not stating that Euclid was wrong for working off of the primary premises of Aristotle to create the fifth postulate. Khayyam understands Euclid’s thought process behind the fifth postulate, including a brief sketch and example into his commentary.

Rather, Khayyam is confused why Euclid would choose to begin with such a complicated postulate without including a discussion, asking “how can one allow Euclid to postulate this proposition [...] while he has demonstrated many things much easier than these?” [8, p. 223]. Khayyam, while appearing to get a bit frustrated, presents an excellent point. Euclid was capable of producing far less complicated propositions from the primary premises of Aristotle. Khayyam provides the example of Euclid III-29: “*In equal circles straight lines that cut off equal circumferences are equal*” [8, p. 223]. The proof of III-29 is extremely short and straightforward. Thus, when comparing it with Euclid’s parallel postulate, Khayyam exclaims “how much will he stand in need of proving something like that!” [8, p. 223]. Even though Euclid derived the parallel postulate using principles taken from Aristotle, it seems that Khayyam believes the it can be conveyed in a simpler way. Therefore, Khayyam chose to address the parallel postulate by claiming Euclid should have started with more natural and “pure” principles which would be “easier to admit” [3, p. 112; 8, p. 219]. It appears that Khayyam’s goal was not to prove the parallel postulate, but rather to rewrite Euclid’s *Elements* in a way that was more natural to the mathematician and to the philosopher.

Interestingly enough, it is not until book I, proposition 29 that Euclid even uses the parallel postulate. This became another common wonder among mathematicians [4, p. 59]. Was the fifth postulate an afterthought that was only added for the demonstration of the 29th proposition? Was it written with haste? Nonetheless, Khayyam accepted the first 28 propositions of book 1, which were based on only the first four of Euclid’s postulates. He began his rewriting of the *Elements* at proposition 29. Khayyam chose two definitions and three principles to begin his discussion, and eight propositions to ultimately replace the parallel postulate [3, p. 115].

Modern mathematicians criticize Khayyam's argument, claiming that his "attempts to eliminate this postulate or deduce it from other axioms, that is, to find a simpler substitute, had failed" [3, p. 122]. Others argue that Khayyam's argument was meant to "justify the parallel postulate", and that "the reader can easily find the mistake in the third theorem of part I" that ultimately caused his eight-proposition argument to fail [1, p. 275]. We will examine these claims and Proposition Three closely, and locate if and where a fatal error occurs in his logic. All of the translated material below was compiled and translated from two modern manuscripts of Khayyam's work [8, p. 215]. Moving forward, all notes in square brackets and all illustrations are mine. Notes in angle brackets are provided by the translator.

DEFINITION 1.1:

The distance between two straight lines situated in the same plane is the straight line which joins them so that the two internal angles are equal.

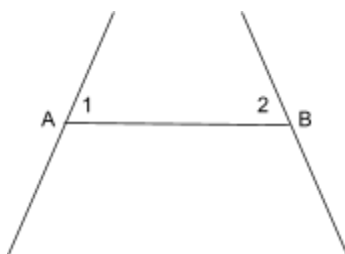

[Let two lines be joined by a line segment AB . If $\angle 1 = \angle 2$, then the length of AB between the point A and the remaining line is the distance between the two lines.]

DEFINITION 1.2:

Two straight lines situated in a same plane diverge in one direction when their distance one from another increases in this direction. -And two lines in the same plane converge in one direction when their distance one from another diminishes in this direction.

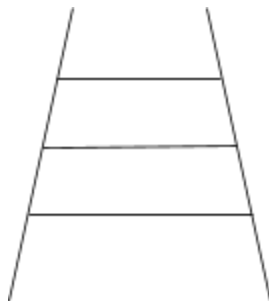
**PRINCIPLE 1.1:**

Two parallel lines are equidistant.

[This was a common principle asserted by Islamic mathematicians. [3, p. 115]]

PRINCIPLE 1.2:

If two straight lines in the same plane diverge in one direction, it is impossible that they converge in the same direction. -And if two straight lines in the same plane converge in one direction, it is impossible that they will diverge in the same direction.

[Two straight lines cannot both converge and diverge in the same direction.]

PRINCIPLE 1.3:

If two straight lines intersect at a point, they will diverge indefinitely, away from the point of intersection.

[Khayyam planned to insert Propositions One through Six into Euclid's *Elements*, and use Propositions Seven and Eight to replace part of Euclid's *Elements*. His scheme for doing so is outlined below.

Euclid's <i>Elements</i>	Khayyam
Proposition 1	
...	
Proposition 28	Proposition One
	Proposition Two
	Proposition Three
	Proposition Four
	Proposition Five
	Proposition Six
Propositions 29, 30	↔ Proposition Seven
Fifth Postulate	↔ Proposition Eight .]

And this is where we begin with the true casual demonstration of this notion with the help of God and His good support.

PROPOSITION ONE,
that is the [new] 29th of Book I [of Euclid's *Elements*].

The line [segment] AB is given. And we draw AC perpendicularly to AB, and we will set BD perpendicularly to AB and equal to the line [segment] AC <they will consequently be parallel, as has been demonstrated by Euclid on proposition 26>, and we will join CD. I say then that the angle ACD is equal to the angle BDC.

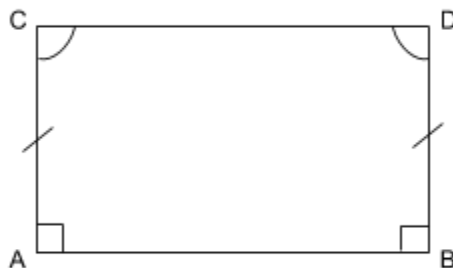

[The discussion of Proposition One is straightforward. Khayyam creates two diagonal lines AD and BC and comes to his conclusion using congruent triangles, a standard Euclidean proof.]

PROPOSITION TWO,
that is the [new] 30th of the *Elements*.

We repeat the figure ABCD [from Proposition One], and we divide AB in two in E, and we draw EG perpendicularly to AB. I say then that CG is equal to GD, and EG perpendicular to CD.

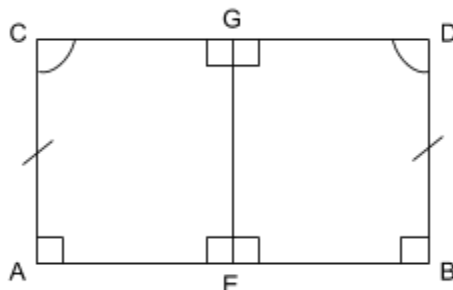

[The proof of Proposition Two is also straightforward. Khayyam creates diagonal lines CE and DE and again comes to his conclusion using congruent triangles.]

PROPOSITION THREE,
that is the [new] 31st of the *Elements*.

And we repeat the figure ABCD [from Proposition One]. I say then that the angles ACD, BDC are right.

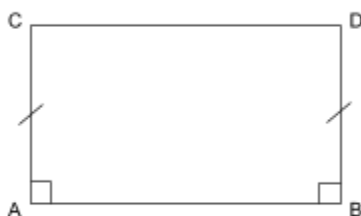

Demonstration. [Proof] We divide [bisect] AB in two halves at E ; and we draw the perpendicular EG [at E . Note that EG is also perpendicular to CD at G by Proposition Two],

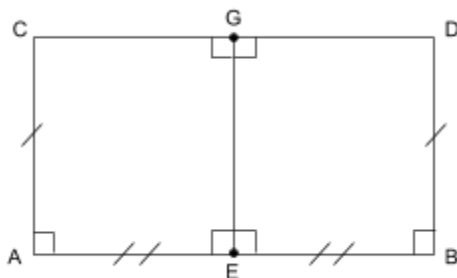

and we produce [extend] it; and we set GK equal to GE ; and we draw HKI [H and I defined below] perpendicularly to EK ; and we produce [extend] AC , BD .

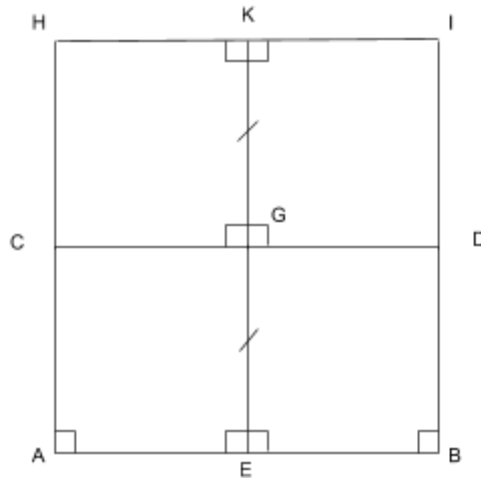

[Claim] Therefore they will cut HKI at H, I .

[Proof of claim] <For AC, EK are parallel;

[Euclid I-27 states: If a straight line $[CG]$ falling on two straight lines $[AC$ and $EK]$ makes the alternate angles $[\angle CGK = \angle EGD]$, both right angles] equal to one another, then the straight lines are parallel to one another. Therefore AC is parallel to EK .]

and HK, GC are also parallel [again, by Euclid I-27]. But whenever there be two parallel lines, the distance between them does not vary. [By Khayyam's Principle 1.1, which states: *Two parallel lines are equidistant.*]

Therefore we produce [extend] to infinity AC parallel to EK [similarly, we extend "to infinity" BD to EK], and we produce [extend] to infinity HK parallel to GC ; and they [the extensions] will inevitably meet these [points H and I].>

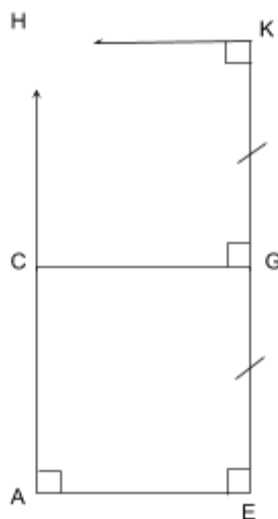

[By Principle 1.1, the distance between GC and HK , and between AH and EK , does not vary. Therefore, these extensions will inevitably meet at a point H . This argument can be replicated for point I . This follows from Khayyam's understanding that Euclid's *Elements* required a continuity axiom of some sort. He mentions this early on in his demonstration, stating "*that magnitudes are divisible ad infinitum, and are not composed of indivisible things* [...] the truth is that this proposition is among the premises of geometry, not among its parts [theorems]. -And notably, *that one can produce a straight line to infinity*" [8, p. 224].]

And we join CK , DK .

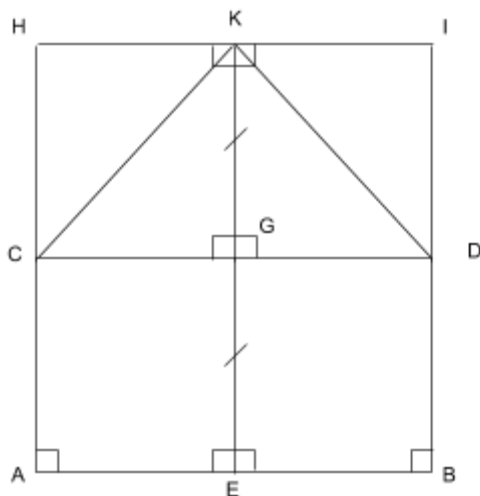

So [in triangles GCK and GDK] the line CG is equal to GD [by Proposition Two]; and GK is common, and it is a perpendicular [by Proposition Two].

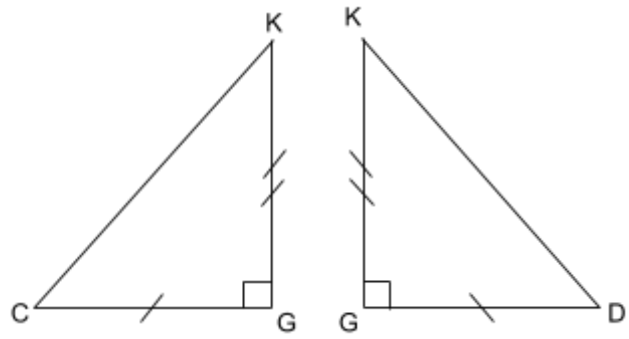

[So by the SAS statement, Euclid I-4, triangles GCK and GDK are congruent.] Therefore the bases CK , KD will be equal, and the angles GCK , GDK will be equal.

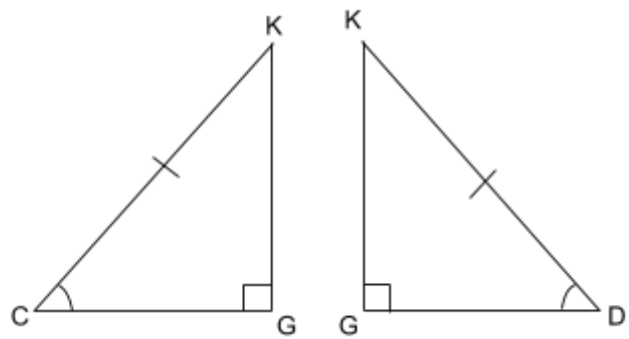

Therefore there will remain the angle HCK equal to KDI . [Note that straight $\angle ACH = \angle ACG + \angle GCK + \angle HCK$ and straight $\angle BDI = \angle BDG + \angle GDK + \angle KDI$. Since $\angle ACH = \angle BDI$, $\angle ACG = \angle BDG$, and $\angle GCK = \angle GDK$, we have $\angle HCK = \angle KDI$.]

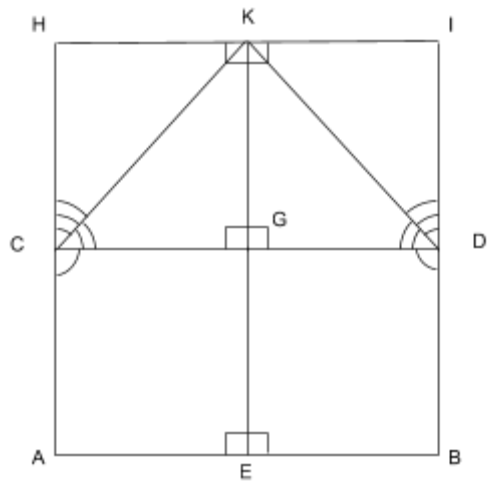

But the angles CKG , DKG are equal [by congruent triangles CKG and DKG]. Therefore there will remain the angles CKH , DKI equal to each other [since as right angles $\angle GKH = \angle GKI$ and $\angle CKG = \angle GKD$]. But the line CK is equal to KD [by congruent triangles CKG and DKG].

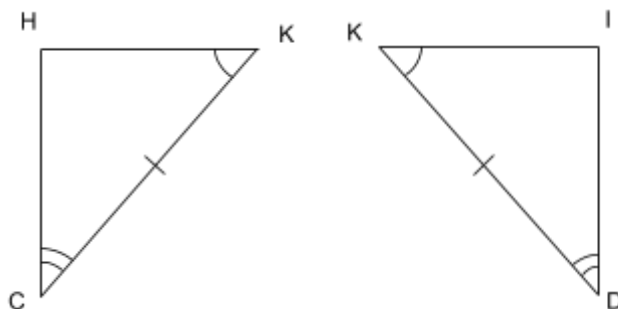

[Thus, by the ASA theorem, Euclid I-26, triangles CKH and DKI are congruent.] Therefore CH will be equal to DI , and HK equal to KI .

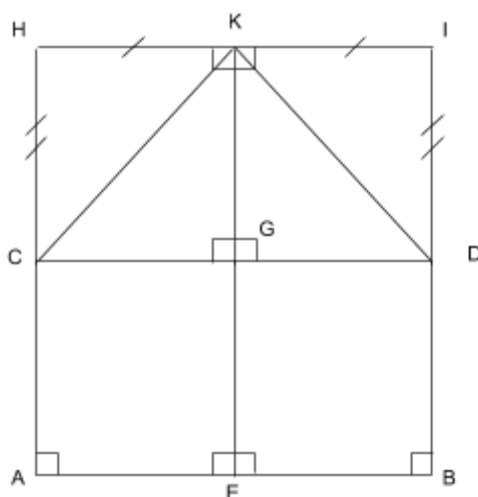

[Given these preliminaries, Khayyam returns to prove his original proposition “*I say then that the angles ACD , BDC are right*”. Recall that by Khayyam’s Proposition One, $\angle ACD = \angle BDC$.]

And if the angles ACD , BDC are right, the statement will be true. But if they are not right, each one of them will either be less than a right <angle>, or greater.

[Case 1: Proof by contradiction] Let it [$\angle ACD = \angle BDC$] first be less than a right <angle>. And we apply the surface [rectangle] HD to the surface [rectangle] CB . [Common notation at the time denoted rectangles by their opposite vertices. Khayyam reflects rectangle HD onto rectangle CB along line segment CD .] GK will therefore apply to [lie on] GE [recall $GK \cong GE$ by construction], and HI to [lie on] AB [since GE is perpendicular to AB and GK is perpendicular to HI].

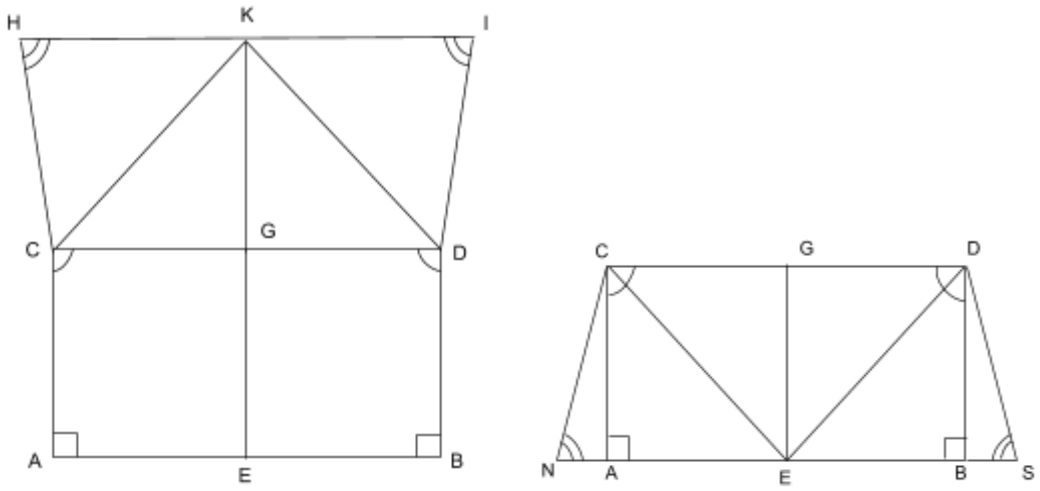

[Claim] Therefore HI will be equal to the line NS [as shown].

[Proof of claim] <For the angle HCG [\cong reflected angle NCG] being greater than the angle ACG , [Since $\angle ACH = 180^\circ$ and $\angle ACG < 90^\circ$, it follows that $\angle HCG > 90^\circ$.] the line HI will be greater than AB . [Since $\angle ACG < 90^\circ$, and $\angle GCN > 90^\circ$, triangle ACN is formed. Therefore NA exists, and $HI > AB$. This argument is repeated for angle GDI .] > [End of proof of claim]

And likewise, if the two lines [CH and DI] be produced [extended] *ad infinitum* [to infinity] in this manner, each of the joined line[s] will be greater than the other, and they will follow one another. [Meaning if CH and DI are extended to infinity in the direction of H and I , then the lines connecting them (CD, HI, PQ, \dots) will continuously get larger ($CD < HI < PQ < \dots$)]

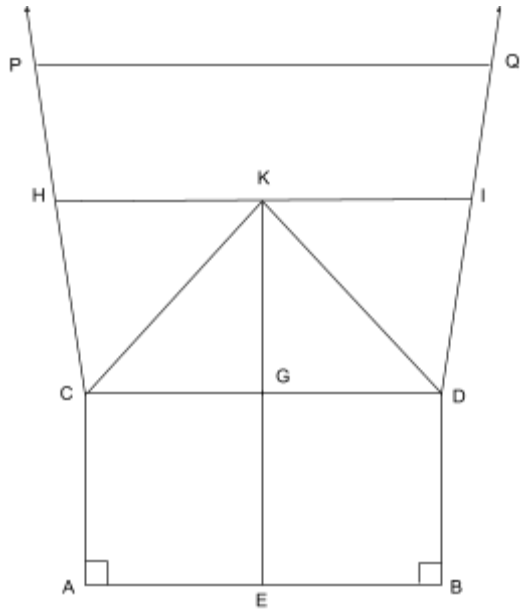

Therefore the lines AC , BD [AH , BI in the original figure] will diverge [in the direction of H and I by Khayyam's Definition 1.2].

And likewise, if AC , BD be produced [extended] in the other direction [in the direction of N and S], they will diverge by the same demonstration; and the state of the two sides will necessarily be similar when applied [illustrated below].

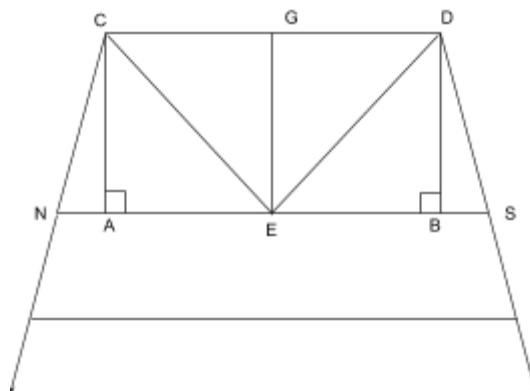

Therefore two straight lines [AH and BI] will cut a straight <line> [CD] according to two right <angles> [meaning the sum of their angles at C and D will each equal 180°], then the distance between them increases on both sides of that line [CD].

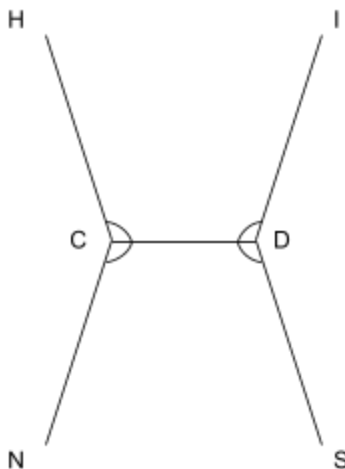

And this is a primary absurdity when straightness be conceived and the distance between the two lines be realized.

[Contradiction. Recall Khayyam's Principle 1.2. Line segments AH and BI are both converging towards CD and then diverging away from CD . Therefore, AH and BI are both converging and diverging in the same direction, which contradicts Principle 1.2.]

<And that is among the things which have already been undertaken by the Philosopher [Aristotle. Khayyam produced Principle 1.2 from similar work by Aristotle. [6, p. 7]].>

[Case 2: Proof by contradiction] And if each of them [$\angle ACD = \angle BDC$] be greater than a right <angle>, the line HI when applied will be equal to LM ; that is less than AB .

[Again, Khayyam reflects rectangle HD over rectangle CB along line segment CD . Since $\angle ACH = 180^\circ$ and $\angle ACD > 90^\circ$, it follows that $\angle GCH < 90^\circ$. Since $\angle CAE = 90^\circ$, triangle CAL is produced within rectangle CB . This argument is repeated on $\angle BDC$. Therefore, $LM < AB$.]

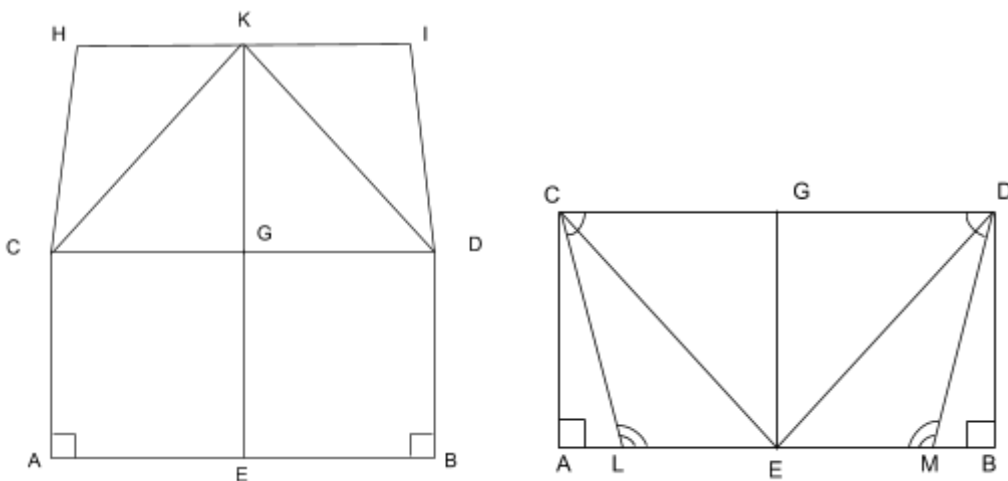

And likewise all the lines which are joined in this manner.

[Khayyam repeats the argument from the acute case. If AH and BI are extended to infinity in the direction of H and I , then the lines connecting them (CD, HI, PQ, \dots) will continuously get smaller ($CD > HI > PQ > \dots$)]

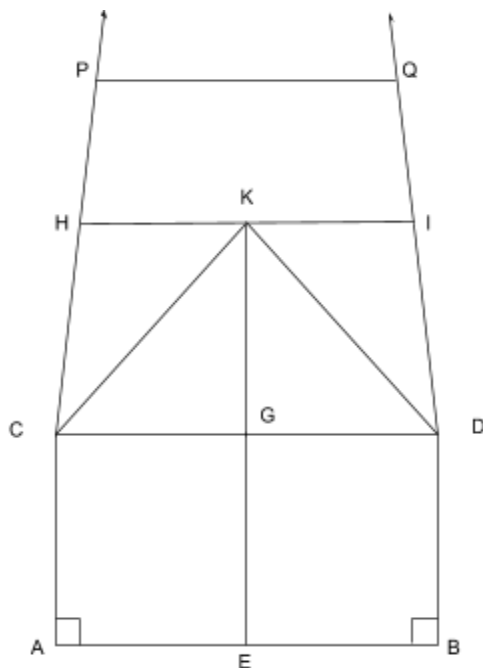

Therefore the two lines [AH and BI] will converge [in the direction of H and I , by definition 1.2].

And if they [AC , BD] be produced [extended] in the other direction [in the direction of L and M], they [CL and DM] will also converge, for the state of the two sides will be similar when applied [illustrated below]. <And that is among the things which you will be able to recognize with a modicum [small amount] of reflection and investigation.>

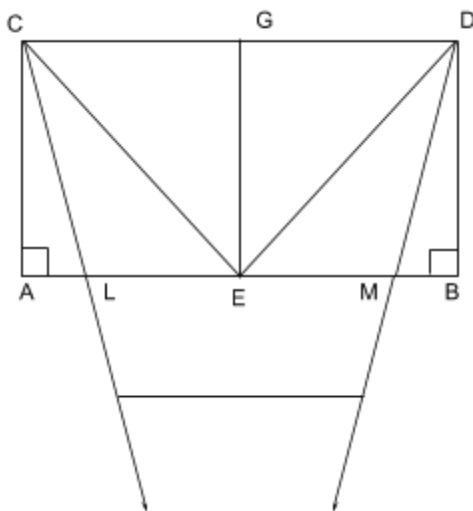

And this is also absurd because of what we have mentioned.

[Line segments AH and BI are both diverging towards CD and then converging away from CD . Therefore, AH and BI are both converging and diverging in the same direction, which contradicts Principle 1.2.]

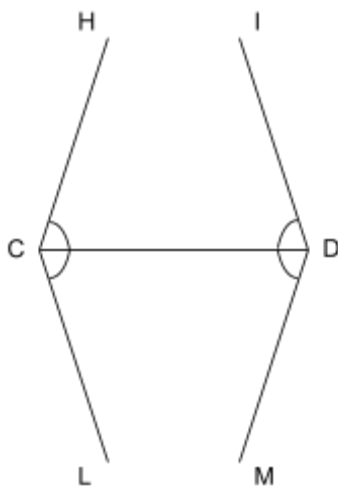

And as it is impossible for the two lines [HI and AB] to be unequal, they will be equal. And as they are equal, the two angles [$\angle ACD = \angle BDC$] will be equal. Consequently, they [$\angle ACD = \angle BDC$] will in that case be two right <angles>. **[End of proof.]**

<One will recognize it with a modicum of reflection, we will therefore omit it to avoid prolixity [wordiness]. So whosoever wants in this place to establish that according to the mathematical order, let him do it; we will not stand in the way!>

[With that, Khayyam has completed Proposition Three. Khayyam restates that his predecessors failed because they were simply overcomplicating their arguments. He also adds an additional definition before proceeding.]

DEFINITION 1.3:

Two straight lines perpendicular to a given straight line are called face-to-face.

PROPOSITION FOUR,

that is the [new] 32nd of the *Elements*.

The surface ABCD is rectangular. I say then that AB is equal to CD, and AD equal to BC.

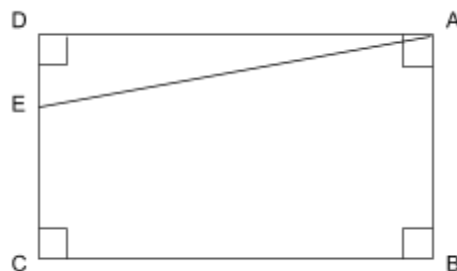

[Khayyam proves Proposition Four by contradiction. He claims that $AB = CE$ and proves this to be impossible using Euclid's proposition I-16, the exterior angle theorem.]

PROPOSITION FIVE,
that is the [new] 33rd of the *Elements*.

The lines AB, CD are face-to-face. I say then that each line which is perpendicular to one of them will then be perpendicular to the other.

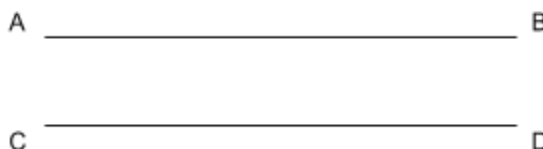

[By "face-to-face", Khayyam means lines which neither converge nor diverge from each other. He proves this proposition by contradiction.]

PROPOSITION SIX,
that is the [new] 34th of the *Elements*.

Whenever there be two parallel lines <as Euclid has defined it, namely those which do not meet, without any other condition>, they will be face-to-face.

[Khayyam now connects his definition of face-to-face, two lines which neither converge nor diverge, with Euclid's definition of parallel lines, two lines which do not meet.]

PROPOSITION SEVEN,
that is the [new] 35th [of the *Elements*].

<This proposition replaces [original] propositions 29, 30 of Book 1 [of Euclid's *Elements*].>

If a straight line falls upon two parallel lines, the alternate angles will be equal to one another, and the exterior angle equal to the interior, and the two interior angles equal to two right <angles>.

[Proposition Seven is almost word-for-word to Euclid's proposition I-29. The translators also claim that this Proposition should replace Euclid I-30: Straight lines parallel to the same straight line are also parallel to one another. The replacement of I-30 is not explicitly justified. Khayyam proves Proposition Seven by utilizing his previous propositions.]

We have thus demonstrated the laws of parallels without having needed the premise we want to demonstrate [the fifth postulate], and that Euclid has postulated. And this is its demonstration:

PROPOSITION EIGHT,
that is the [new] 36th [of the *Elements*].

The line EG is straight; and the lines EA, GC have been drawn from it in such a way that the angles AEG, CGE are less than two right <angles>. I say then that they will meet in the direction of A.

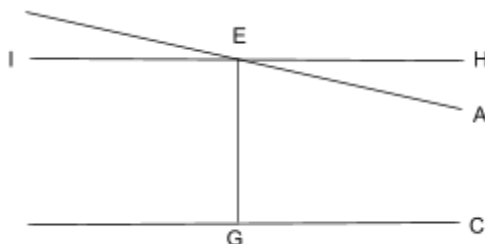

[Note that this is a version of Euclid's parallel postulate. Khayyam begins by stating that $\angle AEG < \angle CGE$ by construction. He draws a third line HI such that $\angle HEG = \angle CGE$. Using his previous propositions, Khayyam claims that HI and GC must be parallel, proving the parallel postulate.]

So this is the true demonstration of the laws of parallels and of the notion which was aimed at. And the truth is, that one should add these propositions to the work the *Elements* according to the order which was mentioned; and take away from it, I mean from this Book, what pertains to the principles and belongs by right to [Aristotle's] First Philosophy <and we have only produced it here, although it be foreign to the art itself, for we could not avoid to produce those sections because of the difficulty of the question and the numerous things which people say about it>, and add what we mentioned to the beginning of the principles. For the art requires it in order to be

brought to philosophical perfection, so that the one which looks into it will not be disturbed with doubts and uncertainties.

And it is time for us to conclude the first Book praising God the Sublime, and blessing the prophet Muhammad and all his family.

With that, Khayyam believed that he had successfully replaced the parallel postulate with his principles and propositions. He believed that his eight propositions should be written into Euclid's *Elements* according to the order mentioned earlier. Since the parallel postulate continued to be the center of attention among some mathematicians for centuries after Khayyam, we know that Khayyam did not succeed in convincing others that he had replaced the parallel postulate.

On the contrary, Khayyam's work sparked criticism. Recall that some mathematicians claimed that Proposition Three contained a fatal error which caused Khayyam's argument to fail. In particular, Proposition Three was the first time that he used Principle 1.1, stating that two parallel lines are equidistant, and Principle 1.2, stating that two lines couldn't both converge and diverge in the same direction. Propositions One and Two did not require any additional principles.

According to the objecting mathematicians, the fatal error in Khayyam's argument was that Principles 1.1 and 1.2 are actually logically equivalent to the fifth postulate itself [8, p. 185].

The translators of Khayyam's work commented upon his use of these equivalent principles, stating that "for him this is not so much a matter of logical equivalence, but rather the fact that principles [One & Two] are *immediate* consequences of the notions of straight line and rectilinear angle, whereas the [fifth] postulate itself is not" [8, p. 185]. It seems that Khayyam believed his two Principles were more natural than the parallel postulate itself, and they should replace it. Since the two Principles are logically equivalent to the fifth postulate, Khayyam has succeeded in creating something "easier to admit" than the fifth postulate without fault.

Nonetheless, for centuries, many mathematicians still criticized Khayyam's work, claiming that by using principles that were equivalent to the parallel postulate, that his replacements and additions to the *Elements* were done "in vain" [1, p. 275]. They claimed that Khayyam's argument failed in the same way that every other mathematician at the time failed to prove the parallel postulate, from, "an error or, more likely, another assumption" [4, p. 59]. However, is it appropriate to conflate Khayyam's attempt with the attempts of others? Was Khayyam's argument a failure, or was it a correct proof of the fifth postulate from Euclid I-1 through I-28 using replacement axioms?

At the same time, others claimed that Khayyam's "attempts to eliminate this postulate or deduce it from other axioms, that is, to find a simpler substitute, had failed" [3, p. 122]. This bit of criticism, in itself, is contradictory. Eliminating or deducing the fifth postulate is not the same as finding a simpler substitute. Even so, we've seen that Khayyam was not attempting to eliminate, deduce, or justify the parallel postulate, as claimed. He was attempting to find a simpler substitute that was "easier to admit", and with that he was successful. Therefore,

contrary to these criticizing mathematicians, there is no fatal error within Khayyam's argument, just a misunderstanding of his original intent.

It is also interesting to note that in his final comments, Khayyam mentions Aristotle's First Philosophy. Recall that Khayyam also used parts of Aristotle's work to produce Principle 1.2. Since Khayyam was a distinguished philosopher, it makes sense that he would continuously mention the work of Aristotle. Today, the First Philosophy is known as metaphysics, a branch of philosophy centered around understanding objects, space, and time in a natural manner [10]. When working under the First Philosophy, the goal is to use only the most natural or basic premises to arrive at the conclusion. In addition, when using the First Philosophy within mathematics, there should be "no unjustified assumptions" [10]. When considering this mention of the First Philosophy, it appears that creating more natural statements than the fifth postulate was exactly what Khayyam was attempting to do. Khayyam was able to create two Principles that were equivalent to the parallel postulate without unjustified assumptions, satisfying the First Philosophy.

Omar Khayyam did not succeed in convincing others to replace the parallel postulate. However, he did succeed in bringing the fifth postulate to "philosophical perfection" [8, p. 233]. Khayyam was able to discover two equivalent principles that were free of "doubts and uncertainties" and indeed easier to admit than the fifth postulate itself [8, p. 233]. Thus, from that point of view, Khayyam's work is done. Omar Khayyam concludes his argument is complete both from a mathematical and philosophical standpoint, and so will I.

With them the seed of Wisdom did I sow,
And with mine own hand wrought to make it grow;
And this was all the Harvest that I reap'd--
"I came like Water, and like Wind I go."

- Omar Khayyam (1048-1131),
translated by Edward Fitzgerald (1859) [5, p. 152]

References

1. Amir-Moez, A., Khayyam, O. (1959). Discussion of difficulties in Euclid. *Scripta Mathematica*. 24: 275-303.
2. Heath, T. L. (1956). *The thirteen books of Euclid's Elements translated from the text of Heiberg with introduction and commentary*. New York: Dover.
3. Kanani, Nasser. (2000). 'Omar Khayyam and the Parallel Postulate. *Farhang*. 12(29-32): 107-124.
4. Katz, V. J. (2009). *A History of Mathematics*, 3rd ed. White Plains, New York: Longman Pub Group.
5. Khayyam, O. (1937). *Rubaiyat of Omar Khayyam*. (Fitzgerald, E., trans.) Garden City, NY: Garden City Publishing Co. Inc.
6. Lamb, E. (2015). What We Knew About Hyperbolic Geometry Before We Knew About Hyperbolic Geometry. Presented at MSRI's Simons Auditorium at UC Berkeley, Berkeley, CA, January 16.
7. O'Connor, J. J., Robertson, E. F. (1999). Omar Khayyam.
<http://www-history.mcs.st-and.ac.uk/Biographies/Khayyam.html>
8. Rashed, R., Vahabzadeh, B. (2000). *Omar Khayyam The Mathematician*. New York: Bibliotheca Persica Press.
9. Struik, D. J. (1958). Omar Khayyam, mathematician. *The Mathematics Teacher*. 51(4): 280-285.
10. Wilshire, B. W., Walsh, W. H., Grayling, A. C. (2018). Metaphysics. *Encyclopædia Britannica*. www.britannica.com/topic/metaphysics